

Maintenance



Our products are designed to require the minimum of maintenance: however the following maintenance procedures will help to ensure the safe and efficient operation of the tricycle.

1) HAND BRAKES

Squirt a few drops of oil on pivot and hand lever. Do not wax or oil rim. Always ensure that your brake blocks are free from oil or grease and regularly check them for wear. If brake blocks are worn they should be replaced. When fitting new brake blocks, ensure that they are the right way up, (narrow edge to the top of the rim nearest to the tyre). Apply the brakes and position the blocks so that they hit the rim squarely and tighten.

2) CONTROL CABLES

Remove cable from the casing and grease inner cable. Replace worn or damaged cables. Do not kink cables. Cables stretch with use, so regular adjustment is necessary.

3) BEARING ADJUSTMENTS

Head bearings - Keep tight and well lubricated. The handlebars must turn freely without any side to side play. Bottom Bracket bearings - The crank assembly should turn freely without side to side play. Keep the locknut tight and ensure the bearings are clean and well adjusted. NOTE: if the Bottom Bracket bearings are not maintained this can result in the chain becoming loose and may result in the Bottom Bracket axle having to be replaced.

4) WHEEL ADJUSTMENTS

Front Wheel - Keep axle nuts tight. There should be no side to side play and the wheel should run smoothly. Adjustments can be made by tensioning or loosening the axle cones. The wheel should be centred in the fork and sitting securely in the fork drop-out. Ensure spokes are tight and the wheel is properly aligned.

Drive Wheel (Riders left hand rear wheel) - This wheel is connected to the axle by an internal thread. This wheel is secured in place with a M 14 Nyloc nut which has been cross drilled and pinned. Ensure that the pin is completely removed before attempting to remove the wheel nut and wheel. Ensure that the spokes are tight and the wheel is properly aligned.

Free Wheel (Riders right hand rear wheel) - This wheel rotates on the axle. The wheel and axle are secured in place by M 12 Nyloc Nuts. If there is side to side movement on this wheel, this can be eliminated by tightening the M 12 lock nuts. Ensure that the spokes are tight and the wheel is properly aligned.

5) PEDALS

Each pedal has a different thread. Forcing the wrong pedal into the wrong crank arm will destroy the threads in the crank arm. To prevent this error, insert the "L" marked pedal into the left crank arm and "R" into the right. Then tighten securely with the wrench.

NOTE: Left and Right are determined from the riding position on the tricycle. Pedal sandals if fitted should be tightened against pedals using the brackets and nuts. The brackets fit to the underside of the pedals and they should be securely tightened in place.

6) CHAIN (See Diagram 2)

It is recommended that a 3 in 1 or similar oil is used to lubricate the chain. Ensure that the chain is properly tensioned, if there is more than 1/4" slack in the middle of the chain then it needs tensioned. This can be achieved by loosening the M 12 Nyloc Frame Stud Nuts and the MB Frame Cap Screw and then pulling the mainframe and rear axle in opposite directions and then tighten the M 12 lock nut and MB screw. Care should be taken not to over tighten the chain as this will make the tricycle difficult to pedal.

7) HANDLEBARS

Ensure that the handlebars and handlebar stem are secured tightly. It is dangerous to ride a tricycle if either is not properly secured. Do not adjust handlebars beyond the maximum mark.

8) SADDLE

Ensure the seat pillar is secured tightly. The saddle should sit squarely on the seat pillar and should not be extended beyond the maximum marker hole.

9) TYRES

Check tyres for proper inflation pressure as indicated on the sidewall. If the tyre is worn or the inner tube is punctured, repairs can be made to the rear wheels without removing the wheel from the axle. The front wheel will need to be removed from the front fork.

10) POSITIONING SUPPORT

Ensure that all positioning supports are properly secured. All screws should be tightened.

11) PULLEY CORD

The foot sandal pulley cord is made of nylon. Should the cord start to wear, heat slowly with a match or candle, until the cord bonds together. Do not overheat or the cord will melt. Regular checks prolong the life of the cord. Ensure that it is running freely through the pulley wheel a silicone spray ensures a smoother operation.

MAINTENANCE INTERVALS

Keep all painted parts cleaned and waxed for a long lasting lustre.

BI-WEEKLY

- Spray all chrome parts with a protective spray
- Lubricate the following: Pivot bolt on brake lever
 - Top of bolt on calliper brake
 - Inside bearing on both pedals
 - Chain-turn pedal crank and spray freely
 - Axle drive cog and axle
 - Axle drive cog
- Check tyre pressure
- Check for loose bolts and nuts
- Crank Arms

3-6 MONTHS

- Check tyres for wear
- Check wheel alignment and for loose spokes
- Check brakes for adjustment, worn cable and worn brake blocks
- Clean and adjust all bearings and cones
- Check chain for adjustment and grime
- Check for loose bolts and nuts
- Check Freewheel axle for excessive side-to-side movement
- Check Drive Wheel for slippage

WARNING! Like any mechanical device, a tricycle and its components are subject to wear and stress. Different materials and mechanisms wear or fatigue at different rates and have different life cycles. If a component's life cycle is exceeded, the component can suddenly fail, causing serious injury. Scratches, cracks and discolouration are signs of stress-caused fatigue and indicate that a part is at the end of its useful life and needs to be replaced.

theraplay
Cycles For Life

www.theraplay.co.uk
www.triaid.com



theraplay
Cycles For Life

TRICYCLES
IMP – TERRIER – TMX – TRACKER



Guarantee



Theraplay Ltd guarantees this frame to be free of defects in material and workmanship from the date of original purchase for a period of 2 years. Our obligation under this guarantee is limited to repair or replacement of any part or entire unit at our option, provided that it has been properly maintained and has not been tampered with or repaired by unauthorised individuals. The guarantee does not cover normal wear and tear, cost of inconvenience, property damage, abuse, accident or similar incidents.

Under these terms, Theraplay Ltd will bear the cost of replacement parts and labour charges, provided reasonable evidence is supplied that the product was purchased within 24 months prior to the claim. The return of any equipment must have prior authorisation and a return shipping and re-delivery charge of £60.00 will be made. Call or write for instructions.

By offering this guarantee, Theraplay Ltd in no way seeks to diminish a consumer's statutory rights.

Congratulations!



You have made an excellent investment in your child's health and happiness. Our tricycles offer valuable exercise and therapy by providing cardiovascular fitness and increased muscle strength.

The following instructions will give you advice on the adjustments and maintenance procedures to enable you to keep your tricycle in the best possible condition. We do, however, recommend that a regular service is carried out by your appointed dealer or a reputable local bicycle shop.

The small cost will help to ensure rider safety and long life of the tricycle.

Please keep this manual in a safe place for future reference.

Recommended Use

- This range of tricycles is designed for recreation and therapy of children with special needs. Riders must have fair head and trunk control to operate the trike effectively.

The tricycle is chain driven and has a fixed gear arrangement which helps to promote muscle development and coordination. Additional supports can be added to the tricycle to tailor it to each child's needs.

THE USE OF A WELL FITTED CYCLE HELMET IS RECOMMENDED

Owners Responsibility

BE SURE TO READ AND CARRY OUT THE FOLLOWING BEFORE THE TRICYCLE IS USED

- READ THE INSTRUCTIONS CAREFULLY AND KNOW HOW TO PROPERLY OPERATE ALL STANDARD AND ACCESSORY EQUIPMENT FURNISHED WITH YOUR TRICYCLE.
- MAKE SURE THAT THE SADDLE AND THE HANDLEBARS ARE POSITIONED TO PROVIDE THE MAXIMUM SAFETY AND COMFORT.
- BEFORE RIDING THE TRICYCLE, BE SURE THAT THE BRAKES ARE CORRECTLY ADJUSTED AND FUNCTION PROPERLY. BE SURE TO TEST THAT YOUR TRICYCLE OPERATES SAFELY AND THAT IT CAN BE BROUGHT TO A SMOOTH SAFE STOP.
- WE RECOMMEND THE USE OF A CYCLE HELMET. IF ONE IS USED, BE SURE IT FITS COMFORTABLY AND SECURELY AND DOES NOT IN ANY WAY INTERFERE WITH VISION OR HEARING.
- OUR TRIKES ARE DESIGNED WITH A LOW CENTRE OF GRAVITY, BROAD WHEELBASE, AND AN ADJUSTABLE STEERING STOP TO MINIMISE THE RISK OF THEM TIPPING OVER, HOWEVER, ALL TRIKES CAN BE TIPPED OVER. ENSURE THAT THE RIDER IS PROFICIENT IN HANDLING THE TRICYCLE ESPECIALLY WHEN CORNERING. IT IS BEST TO CORNER SLOWLY UNTIL CONFIDENCE IS GAINED IN HANDLING THE TRIKE.
- CHECK TYRES FOR PROPER INFLATION PRESSURE AS INDICATED ON THE SIDEWALL.
- ALL TRICYCLES ARE MADE AND ARE INTENDED FOR ONLY ONE PERSON TO RIDE, SITTING PROPERLY ON THE SEAT.

- MAKE SURE THAT ALL NUTS, BOLTS, AND SCREWS ARE SECURELY TIGHTENED.
- THE MANUFACTURER IS NOT RESPONSIBLE FOR FAILURE, INJURY, OR DAMAGE CAUSED BY IMPROPER COMPLETION OF ASSEMBLY OR IMPROPER MAINTENANCE AFTER SHIPMENT.
- SINCE NORMAL WEAR OF SUCH PARTS AS TYRES, TUBES, BRAKE BLOCK ASSEMBLY CABLES, ETC. WILL NECESSITATE REPLACEMENT FROM TIME TO TIME, PLEASE REFER TO YOUR DEALER OR A REPUTABLE BICYCLE SHOP FOR WHATEVER ITEMS ARE REQUIRED.
- INSURE YOUR TRICYCLE.
- RETAIN THESE INSTRUCTIONS IN A SAFE PLACE FOR FUTURE REFERENCE.

Safety Considerations

USE UNDER SUPERVISION.

THE RIDER SHOULD WEAR PROTECTIVE HEADGEAR AND ALWAYS WEAR SHOES.

DO NOT USE NEAR STEPS, SLOPING DRIVEWAYS, ROADWAYS, OR SWIMMING POOLS.

ALTHOUGH OUR PRODUCTS ARE DESIGNED WITH SAFETY IN MIND, WE CANNOT GUARANTEE FREEDOM FROM INJURY. THE USER ASSUMES ALL RISK OF INJURY OR SUITABILITY FOR A PARTICULAR CLIENT.

THE USE OF A WELL FITTED CYCLE HELMET IS RECOMMENDED.

Assembly

YOUR TRICYCLE COMES PARTIALLY ASSEMBLED AND IF BOXED REQUIRES ONE OR MORE OF THE FOLLOWING STEPS.

- Carefully remove the polythene wrapping using a sharp knife and any other packaging material. Care should be taken not to damage the upholstery, tyres and paintwork.
- The tricycle mainframe is split into two parts; the Mainframe Unit and the Rear Unit (see Diagram 1). To assemble these parts first remove the MB cap screw from the Mainframe Unit using the alien wrench provided and then slide this fully into the Rear Unit. Refit the MB cap screw but do not tighten anything at this stage.

* We recommend that before attempting the next stages you protect your clothes and floor covering as this part contains grease

- CHAIN:** To fit the chain, place it onto the front chain ring and then fit it onto the rear cog. If you are unable to fit the chain fully onto the rear cog then place as much chain onto the teeth of the cog as possible and then turn the rear drive wheel (rear left) which will feed the chain onto the cog.

4. ATTACHING FRONT WHEEL FORK TO REAR OF TRIKE (IMP AND TERRIER MODELS ONLY) (See Diagram 4):

To attach front wheel and fork to the rear of tricycle, first remove the two lock nuts at the top of the threaded steering column. Leave one set of ball bearings at the base of the steering column. Insert front wheel and fork upwards into front of tricycle. Fit the other set of ball bearings over the steering column with the ball bearings facing downwards and replace Locknuts on the threaded Column, the broad flat lock nut first, followed by the smaller lock nut. Tighten until the steering can be Turned easily. Over tightening will make the steering stiff.

- ATTACHING FRONT WHEEL FORK TO REAR OF TRIKE (FRAME FOLDING MODELS ONLY):** The same folding mechanism enables the Tricycle to be split into 2 parts for storage and transportation. To join the parts together, remove the black knob and washer from the front section and the black knob with the threaded stud and washer from the rear section. Bring both halves together and reattach the black knobs.

- HANDLEBARS:** Fit the Handlebars and stem into the Steering Column and secure with the Allen key bolt at the top of the Handlebar Stem. Swing the Handlebars into desired position and secure with the Allen key bolt on the underside of the Handlebar Stem. The Handlebars are height adjustable. HINT: Loosen the bolt and then tap the bolt head, this will dislodge the locking mechanism, then secure tightly in place.

- CHAIN TENSION (See Diagram 2):** To tension the chain, pull the Rear Unit back whilst holding the Mainframe Unit, this will effectively stretch the chain. Tighten the MB Frame Cap Screw with the alien wrench and then securely tighten the M 12 Frame Stud Nuts with a 3/4 or 19MM wrench. Turn the pedal to ensure that the chain is running smoothly. The chain tension is correct when the chain has 1/4" of slack in the middle.

- CHAIN GUARD:** The plastic chain guard is pre-drilled and should be fixed to the trike using the self tapping screws which will be attached to the frame.

- SADDLE:** Fit the saddle into the seat post and secure with the locking lever/nut. The saddle is height adjustable but should NOT be extended further than the marker hole on the seat post. The correct saddle height should allow for a slight bend at the knee, when the ball of the foot is on the pedal at its lowest position. The saddle can also be moved horizontally along the seat post or tilted backwards or forwards. The clamp located under the saddle controls this movement.

- BACK/TRUNK SUPPORT:** If your tricycle is supplied with this accessory this unit slides into the square location tubing and secures beneath the saddle. This may be adjusted in depth. The trunk support can be moved vertically. This must be secured in place with the MB Cap Screws.

- FOOT SANDALS WITH PULLEY SYSTEM:** If your tricycle is supplied with this accessory all fittings are provided. Secure with nuts and plate to the underside of the pedal. The pulley wheel should be attached to the frame hook. The cord runs through the pulley wheel and is secured to the underside of each foot sandal. The cord can be adjusted in length to suit the riders requirements or removed.

- KICK STAND:** This is fitted to TMX and Tracker tricycles with folding frame option. NOTE: Do not sit on tricycle when removing the front section of the tricycle as the kick stand is not designed to support the riders weight. The purpose of the kick stand is to assist assembly/disassembly of the folding option.

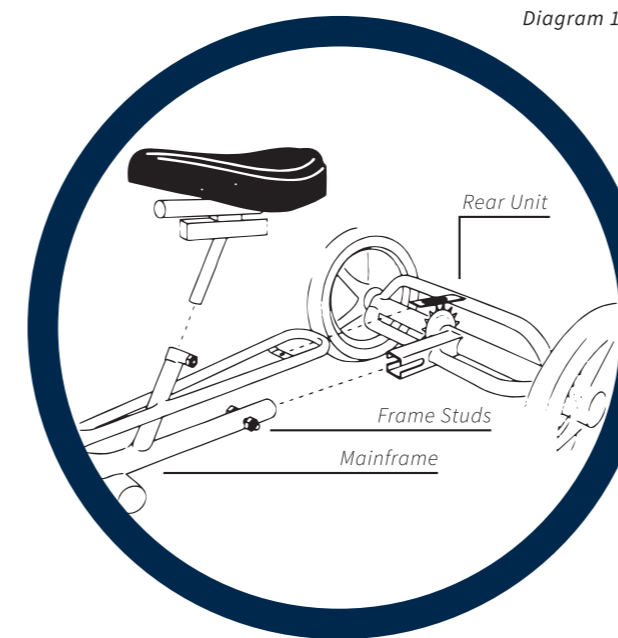

Diagram 1

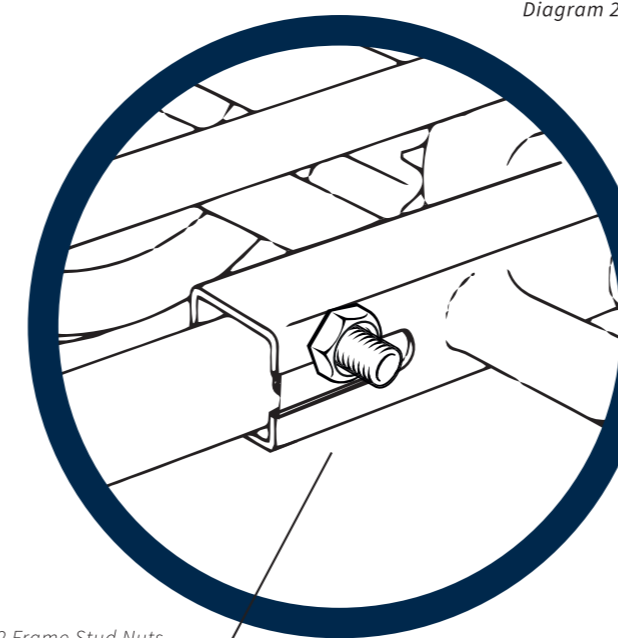

Diagram 2

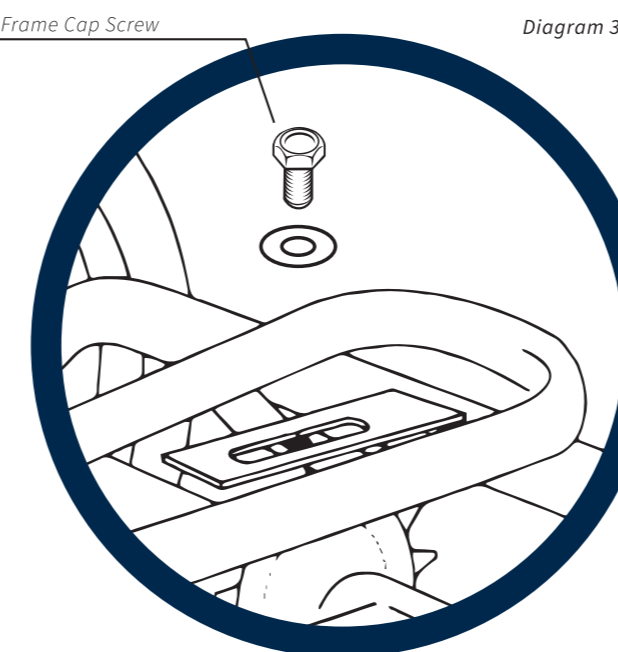
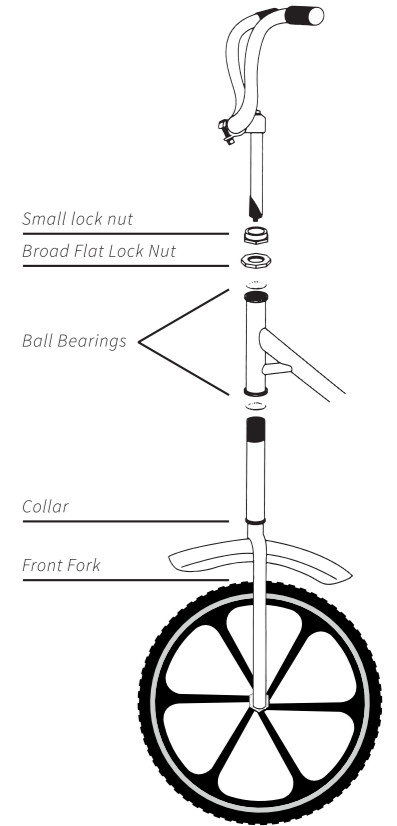

Diagram 3



Diagram 4



Standard Frame Features

The IMP, Terrier, TMX and Tracker models are designed to grow with the rider. Saddle and handlebar adjustments combine with low fixed gearing to ensure that each tricycle will give many years of fun and exercise.

FRONT FORK UNIT: This unit comprises of; front wheel, fork, brake, mudguard, handlebars and stem.

MAINFRAME: This is the central frame of the tricycle and it comprises of; Bottom Bracket assembly, and Headset Bearing assembly. Some models of the tricycle are fitted with a Frame Folding Mechanism which allows the Mainframe to be separated into two sections.

REAR UNIT: This section carries the rear axles and comprises of; drive axle and wheel, free axle and wheel, axle bearings and rear drive cog.

M 12 FRAME STUD NUTS (See Diagram 2): These are located to the rear of the Mainframe and are used to connect the Mainframe and Rear Unit.

M8 FRAME CAP SCREW (See Diagram 3): This is located to the rear of the Mainframe and is used to connect the Mainframe and Rear Unit.

PARKING BRAKE: A calliper brake is fitted to all our Tricycles except the Tracker model which has a 'V' type brake fitted. All Tricycle models, with the exception of the Imp, have a locking brake lever. To operate pull the brake lever whilst pushing down on the silver button, until engaged. To release simply pull on the brake lever.

WHEELS: The Imp has 12 Y2" x 2 1/4" Wheels, The Terrier has 16" x 2.125 Wheels, TMX has 20" x 2.125 Wheels and The Tracker has 24" x 2" Wheels. The left rear wheel is the Drive Wheel. The right rear wheel is the Free Wheel.

STEERING STOP: A steering limitation device is fitted to each tricycle.

TOOLS: 1 x 4/5/6 Allen key and 1 x Inflator (no inflator supplied if puncture proof tyres fitted).

OPTIONAL EQUIPMENT: If you have ordered any of the following accessories please ensure that they have been included. If any of the parts are missing, contact the customer help line.

ADJUSTABLE BACK/TRUNK SUPPORT: This item provides greater sitting stability. It has a U-shaped frame with a waist strap. It is adjustable in height and depth.

FOOT SANDALS C/W PULLEY SYSTEM: Designed to provide assistance in keeping feet on the pedals. The pulley system helps to maintain the foot in a comfortable position.

CUMFI-GRIP HANDLEBAR: A multi adjustable handlebar made in 2 separate halves thus allowing any number of set-up options.

LOOPED HANDLEBAR: Oval shaped handlebar allowing different hand grasp position over conventional type handlebars.

FRAME FOLDING MECHANISM: This item permits the front section of the frame to be folded or detached from the rear for storage or transportation.

PELVIC STRAP: An addition strap which is used in conjunction with a Back/Trunk Support to provide a greater degree of positioning support.

REAR STEERING MECHANISM: Allows complete parent/carer control of the tricycle by means of a rear mounted pole which controls steering of the tricycle. Not available on Tracker model.

LEG CALIPERS: Attachment which is used in conjunction with Foot Sandals to prevent the scissoring action of legs.

PUSH/PULL BAR: This is a detachable guidance pole which can be fitted to the rear of the tricycle for control or the front for steering.

'IN-LINE' TRUNK SUPPORT: A trunk support which provides maximum positioning control. It has adjustable wings which swing away for transfer.