



## Maintenance

Our products are designed to require the minimum of maintenance. However the following maintenance procedures will help to ensure the safe and efficient operation of the tricycle.

### 1) HAND BRAKES

Squirt a few drops of oil on pivot and hand lever. Do not wax or oil rim. Always ensure that your brake blocks are free from oil or grease and regularly check them for wear. If brake blocks are worn they should be replaced. When fitting new brake blocks, ensure that they are the right way up (narrow edge to the top of the rim nearest to the tyre). Apply the brakes and position the blocks so that they hit the rim squarely and tighten.

### 2) CONTROL CABLES

Remove cable from the casing and grease inner cable. Replace worn or damaged cables. Do not kink cables. Cables stretch with use, so regular adjustment is necessary.

### 3) BEARING ADJUSTMENTS

Head bearings – keep tight and well greased. The steering/handlebars must turn freely without any side to side play. Bottom Bracket bearings are a sealed unit.

### 4) PEDALS

Each pedal had a different thread. Forcing the wrong pedal into the wrong crank will destroy the threads in the crank arm. To prevent this error, insert the “L” marked pedal into the left crank arm and the “R” into the right. Then tighten securely with a wrench/spanner.

**NOTE:** Left and Right are determined from the riding position on the tricycle. Pedal sandals, if fitted, should be tightened against pedals using the brackets and nuts. The brackets fit to the underside of the pedals and they should be securely tightened in place.

### 5) CHAIN

It is recommended that a 3 in 1 or similar oil is used to lubricate the chain. Ensure that the chain is properly tensioned. If there is more than ¼” slack in the middle of the chain then it needs tensioned. Please refer to assembly instructions point 6.

### 6) HANDLEBARS

Ensure that the handlebars and handlebar stem are secured tightly. It is dangerous to ride a tricycle if either is not properly secured.

### 7) TYRES

Check tyres for proper inflation pressure as indicated on the sidewall. If the tyre is worn or the inner tube is punctured, repairs can be made to the rear wheels without removing the wheel from the axle. The front wheel will need to be removed from the front fork to access tyre and tube replacement.

### 8) ADJUSTABLE STEERING STOP

Ensure that this adjusted to suit the riders ability.

### MAINTENANCE INTERVALS

Keep all painted parts cleaned and waxed for a long lasting lustre.

### BI\_WEEKLY

- *Spray all chrome parts with a protective spray*
- *Lubricate the following: Pivot bolt on brake lever*  
*Top of bolt on caliper brake*  
*Inside bearing on both pedals*  
*Chain – turn pedal crank and spray freely*  
*Axle drive cog*

- *Check tyre pressure*

- *Check for loose bolts*

- *Crank Arms*

### 3-6 MONTHS

- *Check tyres for wear*
- *Check wheel alignment for loose spokes*
- *Check brakes for adjustment, worn cables and worn brake blocks*
- *Clean and adjust all bearings and cones*
- *Check chain for adjustment and grime*
- *Check for loose bolts and nuts*
- *Check Freewheel axle for excessive side-to-side movement*

**WARNING!** Like any mechanical device, a tricycle and its components are subject to wear and stress. Different materials and mechanisms wear or fatigue at different rates and have different life cycles. If a component's life cycle is exceeded, the components can suddenly fail, causing potential injury. Scratches, cracks and discolouration are signs of stress-caused fatigue and indicate that a part is at the end of its useful life and needs to be replaced.

# theraplay

## Cycles For Life

## TRACER

### User Manual



## Guarantee

Theraplay Ltd guarantees this frame to be free of defects in material and workmanship from the date of original purchase for a period of 2 years. Our obligation under this guarantee is limited to repair or replacement of any part or entire unit at our option, provided that it has been properly maintained and has not been tampered with or repaired by unauthorised individuals. The guarantee does not cover normal wear and tear, cost of inconvenience, property damage, abuse, accident or similar incidents.

Under these terms, Theraplay Ltd will bear the cost of replacement parts and labour charges, provided reasonable evidence is supplied that the product was purchased within 24 months prior to the claim. The return of any equipment must have prior authorisation and a return shipping and re-delivery charge of £60.00 will be made. Call or write for instructions.

By offering this guarantee, Theraplay Ltd in no way seeks to diminish a consumer's statutory rights.

## Congratulations

You have made an excellent investment in your child's health and happiness. Our tricycles offer valuable exercise and therapy by providing cardiovascular fitness and increased muscle strength.

The following instruction will give you advice on the adjustments and maintenance procedures to enable you to keep your tricycle in the best possible condition. We do, however, recommend that a regular service is carried out by your appointed dealer or a reputable local bicycle shop. The small cost will help to ensure rider safety and long life of the tricycle.

Please keep this manual in a safe place for future reference.

# Recommended Use

This range of tricycles is designed for recreation and therapy of children with special needs. Riders must have fair head and trunk control to operate the trike effectively.

The tricycle is chain driven and has a fixed gear arrangement which helps to promote muscle development and coordination. Additional supports can be added to the tricycle to tailor it to each child's needs.

THE USE OF A WELL FITTED CYCLE HELMET IS RECOMMENDED

# Owners Responsibility

- BE SURE TO READ AND CARRY OUT THE FOLLOWING BEFORE THE TRICYCLE IS USED
1. READ THE INSTRUCTIONS CAREFULLY AND KNOW HOW TO PROPERLY OPERATE ALL STANDARD AND ACCESSORY EQUIPMENT FURNISHED WITH YOUR TRICYCLE.
  2. MAKE SURE THAT THE SADDLE AND THE HANDLEBARS ARE POSITIONED TO PROVIDE THE MAXIMUM SAFETY AND COMFORT.
  3. BEFORE RIDING THE TRICYCLE, BE SURE THAT THE BRAKES ARE CORRECTLY ADJUSTED AND FUNCTION PROPERLY. BE SURE TO TEST THAT YOUR TRICYCLE OPERATES SAFELY AND THAT IT CAN BE BROUGHT TO A SMOOTH SAFE STOP.
  4. WE RECOMMEND THE USE OF A CYCLE HELMET, IF ONE IS USED, BE SURE IT FITS COMFORTABLY AND SECURELY AND DOES NOT IN ANY WAY INTERFERE WITH VISION OR HEARING.
  5. OUR TRIKES ARE DESIGNED WITH A LOW CENTRE OF GRAVITY, BROAD WHEELBASE, AND AN ADJUSTABLE STEERING STOP TO MINIMISE THE RISK OF THEM TIPPING OVER, HOWEVER, ALL TRIKES CAN BE TIPPED OVER. ENSURE THAT THE RIDER IS PROFICIENT IN HANDLING THE TRICYCLE ESPECIALLY WHEN CORNERING. IT IS BEST TO CORNER SLOWLY UNTIL CONFIDENCE IS GAINED IN HANDLING THE TRIKE.
  6. CHECK TYRES FOR PROPER INFLATION PRESSURE AS INDICATED ON THE SIDEWALL.
  7. ALL TRICYCLES ARE MADE AND ARE INTENDED FOR ONLY ONE PERSON TO RIDE, SITTING PROPERLY ON THE SEAT.
  8. MAKE SURE THAT ALL NUTS, BOLTS, AND SCREWS ARE SECURELY TIGHTENED.
  9. THE MANUFACTURER IS NOT RESPONSIBLE FOR FAILURE, INJURY, OR DAMAGE CAUSED BY IMPROPER COMPLETION OF ASSEMBLY OR IMPROPER MAINTENANCE AFTER SHIPMENT.
  10. SINCE NORMAL WEAR OF SUCH PARTS AS TYRES, TUBES, BRAKE BLOCK ASSEMBLIES, CABLES, ETC. WILL NECESSITATE REPLACEMENT FROM TIME TO TIME. PLEASE REFER TO YOUR DEALER OR A REPUTABLE BICYCLE SHOP FOR WHATEVER ITEMS ARE REQUIRED.
  11. INSURE YOUR TRICYCLE
  12. RETAIN THESE INSTRUCTIONS IN A SAFE PLACE FOR FUTURE REFERENCE.

# Standard Frame Features

**FRONT FORK UNIT:** This unit comprises a quick release front wheel with MTB Disc Brake, V-Brakes, mudguard, handlebar and multi adjustable handle bar stem.

**MAINFRAME:** This is the central frame of the tricycle and comprises the Bottom Bracket (cartridge type) assembly, Headset Bearing assembly. Some models of the tricycle are fitted with a Frame Folding mechanism that allows the mainframe to be separated into two sections.

**REAR UNIT:** This section carries the rear axles and comprises of a drive axle and wheel, free axle and wheel, axle bearings and rear drive cog.

**M12 FRAME STUD NUTS (SEE DIAGRAM 1):** These are located to the rear of the mainframe and are used to connect the Mainframe and Rear Unit.

**CHAIN TENSION:** Directly beneath the M12 Frame Stud Nuts is a chain tension screw that should be adjusted to reduce slack on your chain. There should only be approx. 1/4" slack on the chain.

**PARKING BRAKE:** The Tracer is fitted with two brakes, both operating on the front wheel. One lever will operate the V-Brake whilst the other lever operates the front disc brake on the left side of the wheel. Your Tracer tricycle also has a locking brake lever to immobilise the tricycle during transfer on/off. To operate pull the brake lever whilst pushing down on the silver button, until engaged. To release simply pull on the brake lever (see diagram 4).

**WHEELS:** The Tracer has a 20" x 2.125 Front wheel and two 24" x 2.125 Rear wheels. Tracer Junior models have three 20" x 2.125" wheels. The left rear wheel is the Drive Wheel. The right rear wheel is the Free Wheel.

**STEERING STOP:** A steering limitation device is fitted to each tricycle and can be found just above the front mudguard (socket cap screw) on the Tracer tricycle.

**PEDALS:** All Tracer models as standard have Self Balance Pedals fitted together with toe clip & strap. Optional pedal supports can be supplied.

**TOOLS:** 1 x 41516 Allen key and 1 x Inflator (no inflator supplied if puncture proof tyres fitted)

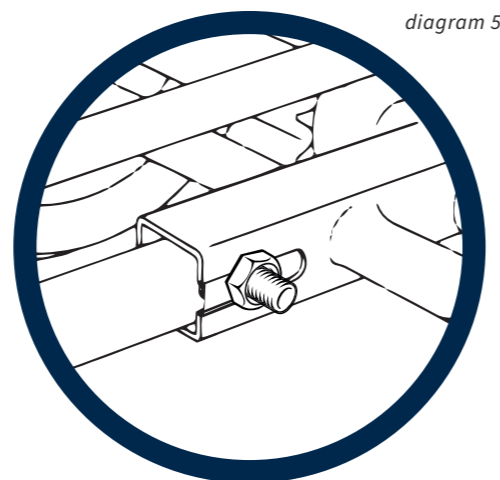

diagram 5

# Assembly

YOUR TRICYCLE COMES PARTIALLY ASSEMBLED AND IF BOXED REQUIRES ONE OR MORE OF THE FOLLOWING STEPS.

1. Carefully remove the polythene wrapping and any other packaging material with a sharp knife. Care should be taken not to damage the upholstery, tyres and paintwork.
2. The tricycle mainframe is split into two parts: the Mainframe Unit and the Rear Unit (see diagram 1). Slide Mainframe Unit fully into Rear Unit. Do not tighten M12 Stud Lock Nuts at this time.

\* We recommend that before attempting the next stages you protect your clothes and floor covering as this part contains grease.

3. **CHAIN:** To fit the chain, place it into the front chainring and then fit onto the rear cog. If you are unable to fit the chain fully onto the rear cog then place as much chain onto the teeth of the cog as possible and then turn the rear drive wheel (rear left) which will feed the chain onto the cog.

4. **ATTACHING FRONT WHEEL/FORK TO REAR TRIKE**  
The frame folding mechanism enables the tricycle to be split into 2 parts for storage and transportation (see diagram 2). To join the parts together, remove the black knob and washer from the front section and the black knob with the threaded stud and washer from the rear section. A kickstand is located on the Rear Mainframe Unit and should be folded down at this stage. Bring both halves together and re-attach the black knobs.

5. **HANDLEBAR**  
These are already attached but will require moving to the desired position for the rider. To adjust angle of handlebar, slide the black button forwards and lift lever at the same time (see diagram 4). This enables both height and angle of handlebar to be set. To lock in position simply depress lever.

6. **CHAIN TENSION**  
To tension the chain, pull the Rear Unit back whilst holding the Mainframe Unit as this will effectively stretch the chain. Located beneath the 2 Stud Lock Nuts is a threaded screw that acts as a chain tensioner. By threading the screw inwards it will gradually put more tension on the chain. Continue until chain has approx. 1/4" slack in the middle. Finally tighten the two M12 Stud Lock Nuts with a 3/4" or 19mm wrench. Turn the pedal to ensure that the chain is running smoothly.

7. **CHAINGUARD**  
The plastic chain guard is pre-drilled and should be fixed to the trike using the self-tapping screws which you will find attached to the frame. Once fitted then thread on Right Hand pedal and tighten securely.

8. **SEAT (see diagram 3)**  
Your Tracer seat locates onto the Mainframe Unit by means of square peg. The security locking pin and lanyard should be placed through the locating hole on the square peg. Pushing on the seat lever much like an automobile, enables fore and aft adjustment of the seat.

9. **KICKSTAND**  
The purpose of the kickstand is to assist assembly/disassembly of the folding option. NOTE: Do not sit on the tricycle when removing the front section of the tricycle as the kickstand is not designed to support the riders weight.

10. **REAR WHEELS**  
In some cases it may be necessary, for packaging, to remove the rear wheels. The rear wheels slide over the rear axle and are held in place by an M12 Nylock Nut. Each wheel hub has a circular hole with a small square key cut into the hub. Embedded at each end of your Tracer axle is a corresponding steel key. Align slot and keyway and slide onto the axle. NOTE: each hub is recessed and should be facing outwards with the thread of the axle showing. Attach the M12 Nylock Nut and tighten until wheel runs freely.

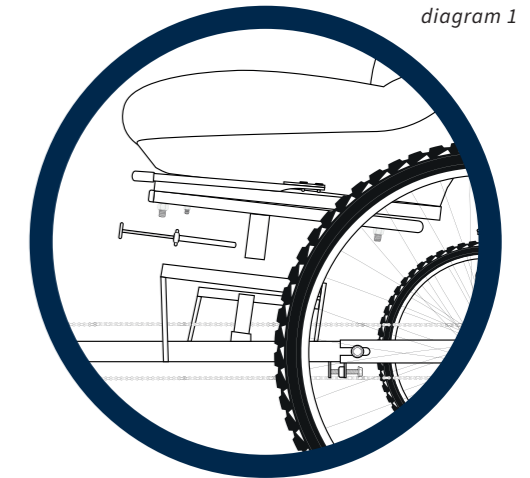

diagram 1

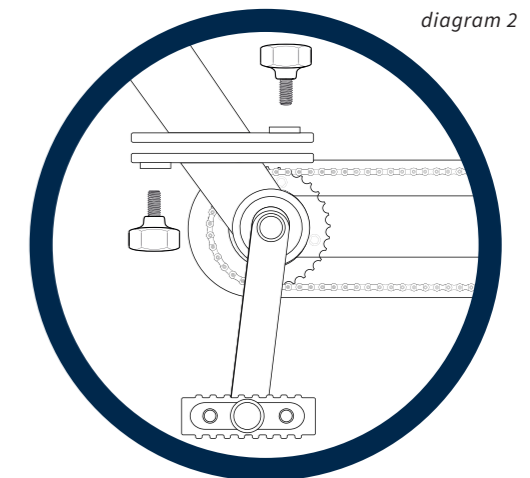

diagram 2

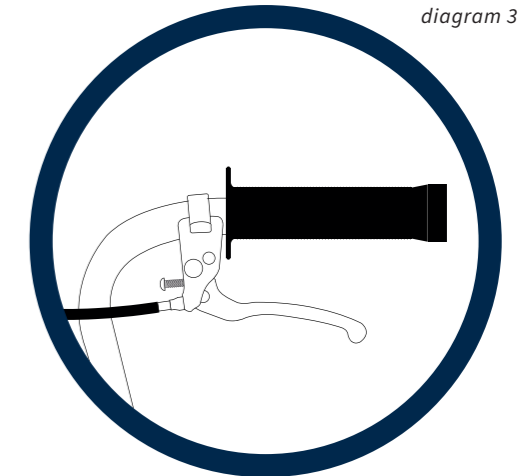

diagram 3

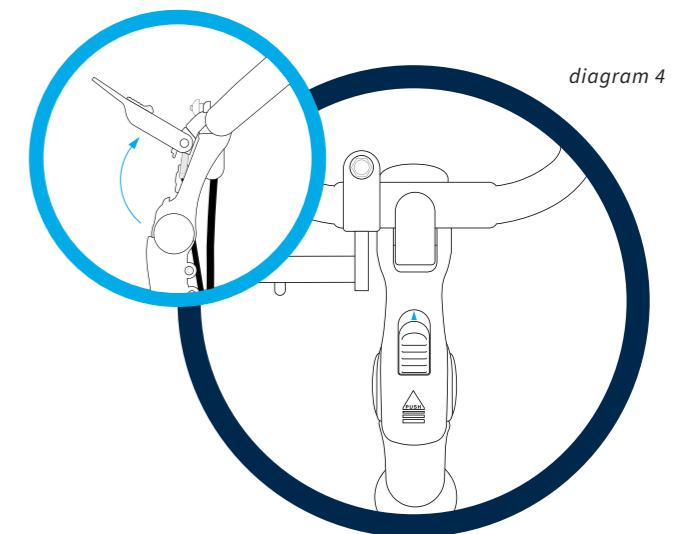

diagram 4